



Consulting, help, education

INTERNATIONAL JOURNAL OF ENGINEERING SCIENCES & MANAGEMENT

POWER QUALITY ENHANCEMENT IN THREE PHASE SYSTEM

Ashish Dewangan^{1*} and Vineet Dewangan²

Dept. of Electrical & Electronics, SSITM, Junwani Bhilai, (CG) - India

ABSTRACT

This paper presents a literature survey and review on enhancement of performance parameters of three phase system either for machines or various receiving end stations, connected in 3 phase three wire or four wire system by using FACTS devices. Power Quality, in terms of power factor and harmonics, is greatly hampered by a three phase rectifier used as a front-end ac-to-dc converter in many systems including a UPS. The setup is tested for power factor correction and voltage regulation along with neutral current compensation harmonic elimination, and balancing of linear loads as well as nonlinear loads.

Key words: DSTATCOM, T connected transformer, VSC, PFC circuit.

INTRODUCTION

The term "Power Quality" means different things to different people. One definition is the relative frequency and severity of deviations in the incoming power supplied to electrical equipment from the steady 50 Hz, sinusoidal waveform of voltage or current. These deviations may affect the safe or reliable operation of equipment such as computers. Thus terms like "poor power quality" mean that there is ample deviation from norms in the power supply that may cause equipment malfunction or failure. In certain commercial and industrial electrical applications, it is critical that high quality and uninterrupted power be supplied; for fear that significant economic losses can be incurred.

Power Frequency Variations are defined as the deviation of the power system fundamental frequency from its specified nominal value (e.g. 50 Hz or 60 Hz). The power system frequency is directly related to the rotational speed of the generators supplying the system. There are slight variations in frequency as the dynamic balance between load and generation changes.

The size of the frequency shift and its duration depends on the load characteristics and the response of the generation control system to load changes. Frequency variations that go outside of accepted limits for normal steady state operation of the power system can be caused by faults on the bulk power transmission system, a large block of load being disconnected, or a large source of generation going offline.

THREE-PHASE FOUR-WIRE GRID-INTERFACING POWER QUALITY COMPENSATOR

The general layout of the proposed grid interfacing power quality compensator. The compensator consists of two four-phase-leg inverters, namely inverter A (shunt) and inverter B (series). The main functions of inverter A are to maintain a set of balanced sensitive load voltages within the micro-grid even under unbalanced load and grid voltage conditions, generate and dispatch power, share the power demand optimally with the other parallel-connected DG systems when the micro-grid islands, and to synchronize the micro-grid with the utility system at the instant of connection. On the contrary, the main function of inverter B is to maintain a set of balanced line currents by introducing negative- and zero-sequence voltages to compensate for the grid voltage unbalance.

*Corresponding Author

Email – dewangan.vineet@gmail.com

ashish_shp@yahoo.co.in

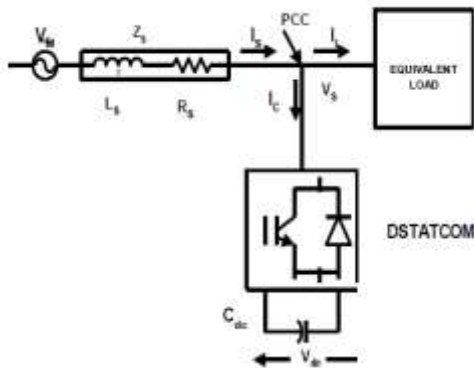

Fig. 1 DSTATCOM system diagram

Fig. 1 shows the single-line diagram of the shunt-connected DSTATCOM based distribution system. The dc capacitor connected at the dc bus of the converter acts as an energy buffer and establishes a dc voltage for the normal operation of the DSTATCOM system. The DSTATCOM can be operated for reactive power compensation for power factor correction or voltage regulation.

The proposed DSTATCOM consisting of a three-leg VSC and a T-connected transformer is shown in Fig.2, where the T-connected transformer is responsible for neutral current compensation.

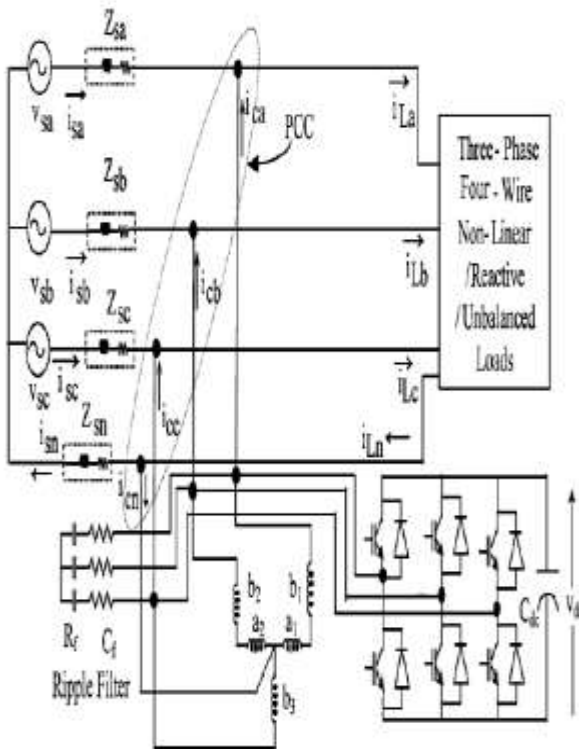

Fig. 2 Proposed schematic diagram of VSC with T connected Transformer based DSTATCOM

CONTROL OF D-STATCOM

The control approaches available for the generation of reference source currents for the control of the VSC of DSTATCOM for three-phase four-wire system are instantaneous reactive power theory (IRPT), synchronous reference frame theory (SRFT), unity power factor (UPF) based, instantaneous symmetrical components based, etc. The SRFT is used in this investigation for the control of the DSTATCOM. A block diagram of the control scheme is shown in Fig. 3.

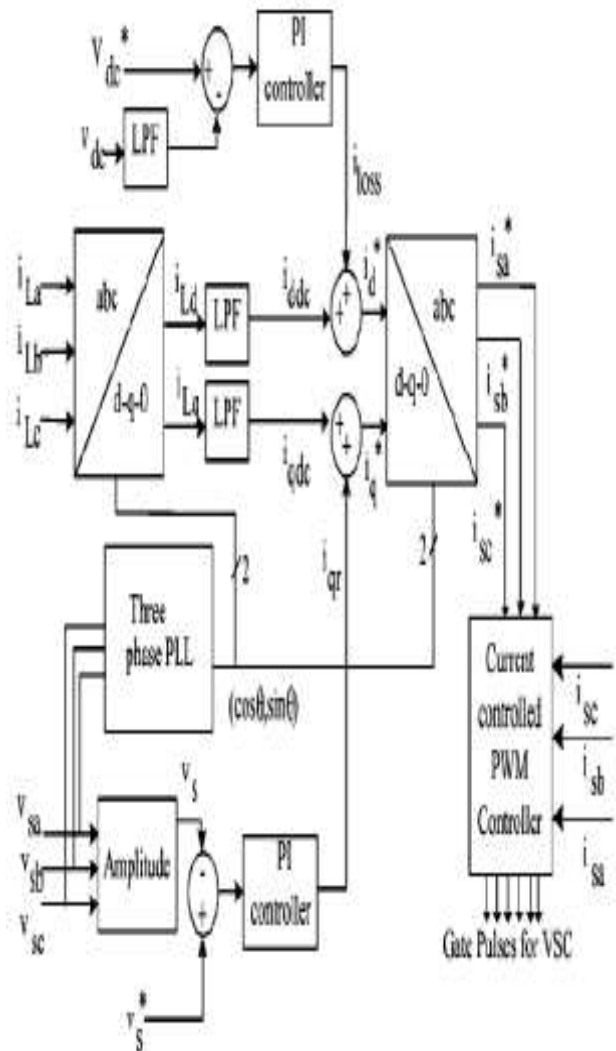

Fig. 3 Control Scheme for VSC with T connected Transformer based DSTATCOM

The load currents (i_{La} , i_{Lb} , i_{Lc}), the PCC voltages (V_{Sa} , V_{Sb} , V_{Sc}), and dc bus voltage (V_{dc}) of DSTATCOM are sensed as feedback signals. The load currents from the $a-b-c$ frame are first converted to the $a-\beta-o$ frame and then to the $d-q-o$ frame using

$$\begin{bmatrix} i_{Lq} \\ i_{Ld} \\ i_{Lo} \end{bmatrix} = \begin{bmatrix} \cos \theta & \cos(\theta - \frac{2\pi}{3}) & \cos(\theta + \frac{2\pi}{3}) \\ \sin \theta & \sin(\theta - \frac{2\pi}{3}) & \sin(\theta + \frac{2\pi}{3}) \\ \frac{1}{2} & \frac{1}{2} & \frac{1}{2} \end{bmatrix} \begin{bmatrix} i_{La} \\ i_{Lb} \\ i_{Lc} \end{bmatrix}$$

where $\cos \theta$ and $\sin \theta$ are obtained using a three-phase phase locked loop (PLL). A PLL signal is obtained from terminal voltages for generation of fundamental unit vectors (S. Bhattacharya and D. Diwan, 1995) for conversion of sensed currents to the $d-q-o$ reference frame. The SRF controller extracts dc quantities by a low-pass filter, and hence, the non-dc quantities (harmonics) are separated from the reference signal. The d -axis and q -axis currents consist of fundamental

and harmonic components as

$$i_{LD} = i_{d\ dc} + i_{d\ ac}$$

$$i_{LQ} = i_{q\ dc} + i_{q\ ac}$$

THREE-PHASE FRONT-END RECTIFIER OF UPS SYSTEM USING CURRENT INJECTION TECHNIQUE

The proposed ac-to-ac converter is shown in Figure 4. It mainly consists of PFC circuit and a soft-switched inverter for zero voltage and zero current transitions.

The PFC circuit consists of three phase inverter, capacitors C_f and switched inductors L_f . The inverter is switched with high frequency. The high-frequency (HF) current is injected at the input of three-phase diode bridge rectifier through capacitor C_f causing modulation of input voltage of the diode bridge rectifier. This forces the diodes of the three phase bridge rectifier to turn-on and turn-off at the switching frequency over the complete cycle of the input supply voltage. In a switching cycle, the input current is the sum of average values of injected current i_{Cf1} and i_{Lf1} , as shown in Figure. Average value of i_{Cf1} over a switching cycle is zero and peak value of i_{Lf1} follows an envelope of the input supply phase voltage. In each switching cycle this current is reset to zero. Therefore average value of i_{Lf1} also follows the envelope of input voltage. When none of the diodes conducts then supply current flows through C_f . Thus LS operates in continuous conduction mode (CCM). therefore the input current is always in phase with the input supply phase voltage, v_s . Hence the converter operates at high-power-factor. For CCM the output voltage of the rectifier should be twice the peak value of input phase voltage

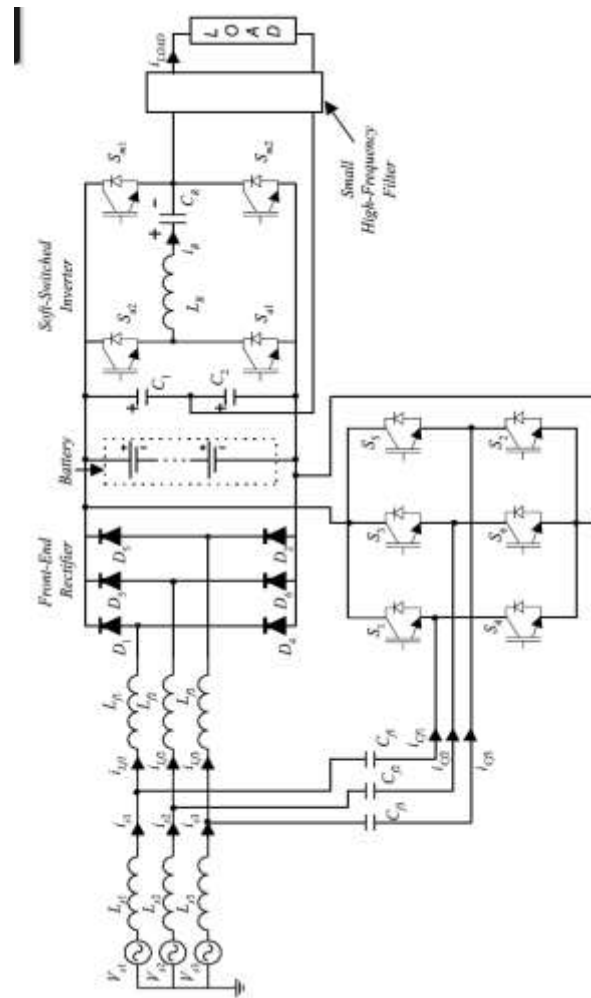

Fig. 4 proposed ac- ac converter PFC circuit

The total three phase input power is given by:

$$P_i = 3 \cdot \frac{1}{2\pi} \int_0^{2\pi} V_s \cdot I_s \cdot d(\omega t)$$

The value of the switched inductor is given by

$$L_f = \frac{3 \cdot V_2 \cdot d}{4 \cdot f_s \cdot P_i}$$

If, P_0 is the output power of the converter, then:

$$L_f = \frac{3 \cdot V_2 \cdot d \cdot \eta}{4 \cdot f_s \cdot P_0}$$

where,

V_s — supply phase voltage
 V_m — peak value of phase voltage d — duty cycle of the inverter
 η — efficiency of the converter
 f_s — switching frequency

SIMULATION RESULTS

(a) Three-phase four-wire grid-interfacing power quality compensator simulation waveform

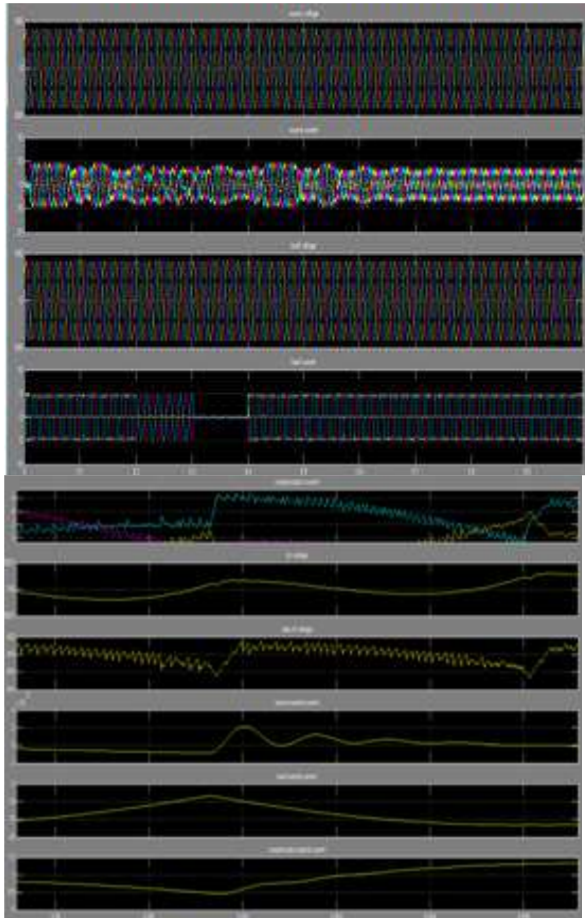

Fig 5(a) Performance of DSTATCOM with Non-Linear Load for Harmonic compensation, Load Balancing.

(b) PFC circuit waveform results

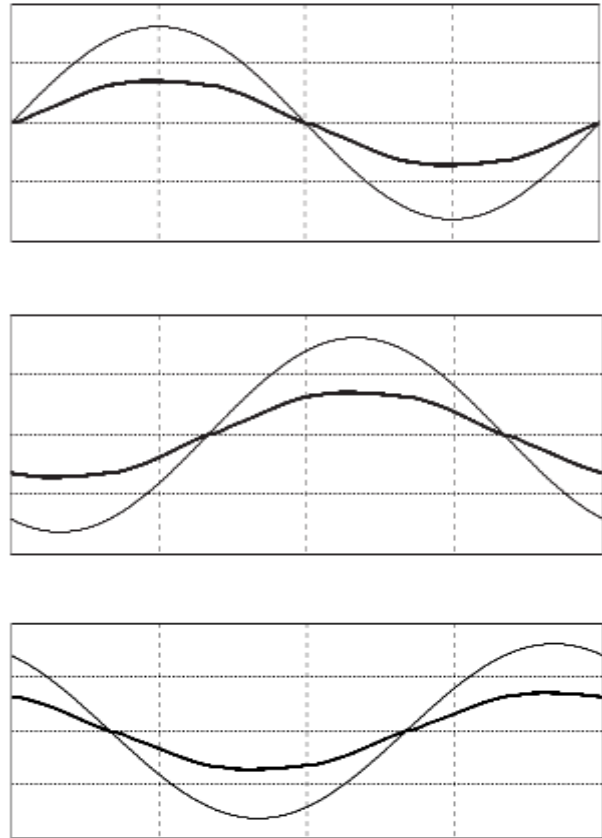

Fig. 5b(i),(ii)&(iii). Simulated waveforms of supply voltage and current. Scale:200 V/div, 10 A/div, 5 ms/div.

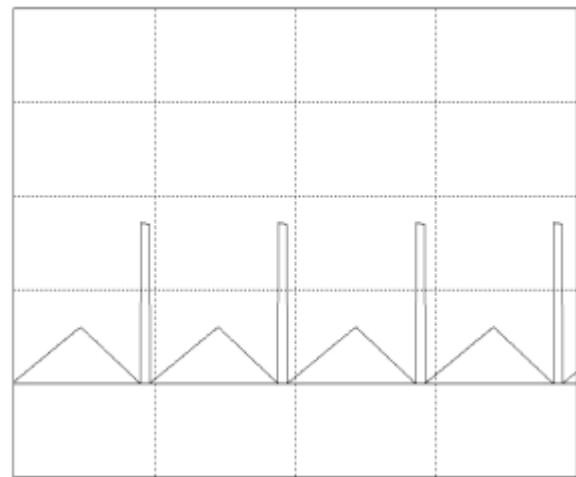

Fig. 5b(iv). Simulated waveforms: Rectifier voltage and current. Scale:200 V/div, 20 A/div, 20µs/div

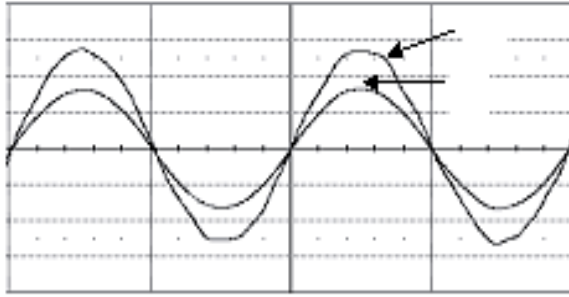

Fig. 5(c) Experimental waveforms of supply voltage and current. Scale:200 V/div, 2 A/div, 10 ms/div

Quality compensator of T connected system and current injection PFC circuit maintains the imbalance which clearly means it reduces the imbalance and sagging swelling notches of the system fig 5a shows the three-phase four-wire grid-interfacing power quality compensator simulation waveform. Simulation results shows the invariable characteristics but at the positive side the voltage profile goes on enhancing. In fig 5b complete PFC circuit waveform results provide a chance for better functioning in a system whether a load is connected or not.

CONCLUSION

Two separate system of quality power enhancement gives meaningful output. Out of which the transformer has mitigated the source neutral current. The dc bus voltage of the DSTATCOM has been regulated to the reference dc bus voltage under all varying loads. Switching of main and auxiliary switches are achieved thereby greatly reducing the switching losses and EMI emissions. The authors strongly believe that this survey article will be very much useful to the researchers for finding out the relevant references as well as the previous work done in the field of reduction of harmonic and improvement of the proposed system. Even though, excellent advancements have been made in classical method

i.e. harmonics distortion factor they suffer with the following disadvantages: It needs large inductance to generate constant current source and since current is limited, the dynamic response of system is slow.

REFERENCES

- [1] FACTS Overview, IEEE and CIGRE joint publication 95 TP 108, April 1995.
- [2] N. G. Hingorani and L. Gyugyi, Understanding FACTS, New York: IEEE Press. 2000.
- [3] Apparatus and Systems, Vol. PAS-96, No.5, pp. 1565-1572, sep/oct 1971
- [4] Szuki Hirokazu, Aajima Tatsugito, Development and testing of prototype models for a high-performance 300 MW self commuted AC/DC converter," IEEE Transactions on Power Delivery, vol.12, pp. 1589 -1597, April 1997.
- [5] A textbook on "Power System Analysis" C.L Wadhwa.
- [6] Micro-Grid Power Quality Enhancement Using A Three-Phase Four-Wire Grid-Interfacing Compensator, vol 5 ,2004 IEEE ,IAS p.p 1439-1446.
- [7] "Power Quality Enhancement Using VSC Based DSTATCOM", International Journal of Engineering and Technology Volume 2 No. 1, pp 93-98 January, 2012.
- [8] "Power Quality Enhancement of Three-Phase Front-End Rectifier of UPS System Using Current Injection Technique", Visvesvaraya National Institute of Technology, Nagpur, India pp 33-39
- [9] "Enhancement of Performance Parameters of Three Phase Induction Motor by Current Source Inverter: An Overview and Key Issues", IJCSAI Vol.1 Issue 1 2011 PP.18-26